

A positive control for engine oil temperature for use in conjunction with all types of oil cooler including vehicle manufacturers original equipment.

OTRFH1L - Left to Right Flow

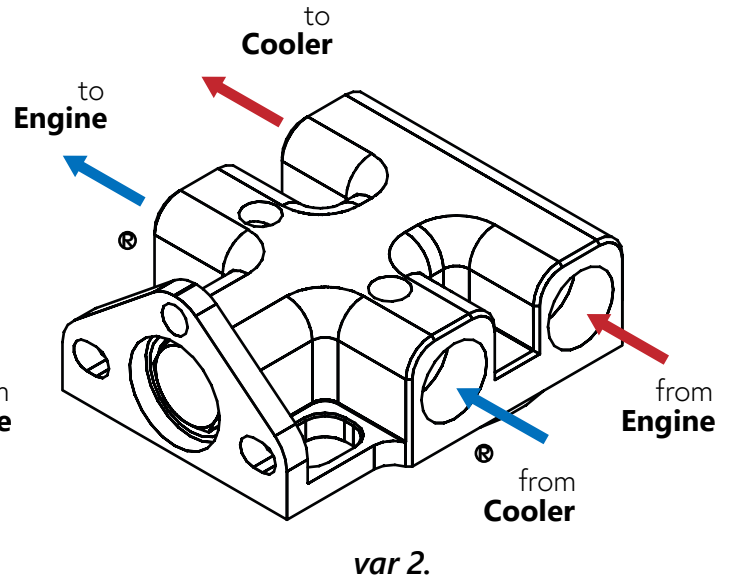
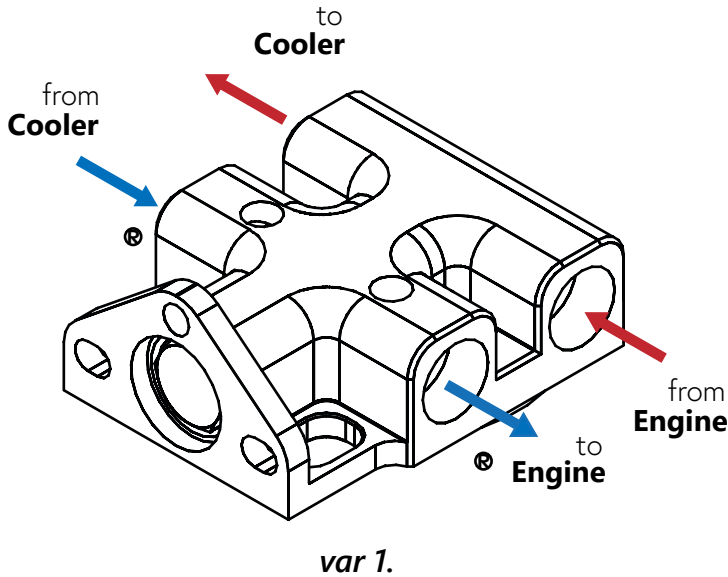

Port threads are M22x1.5

OTRFH1R - Right to Left Flow

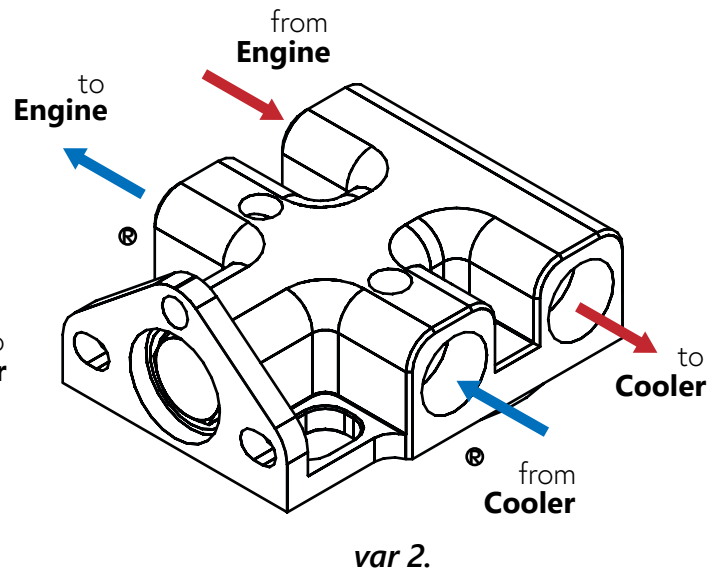
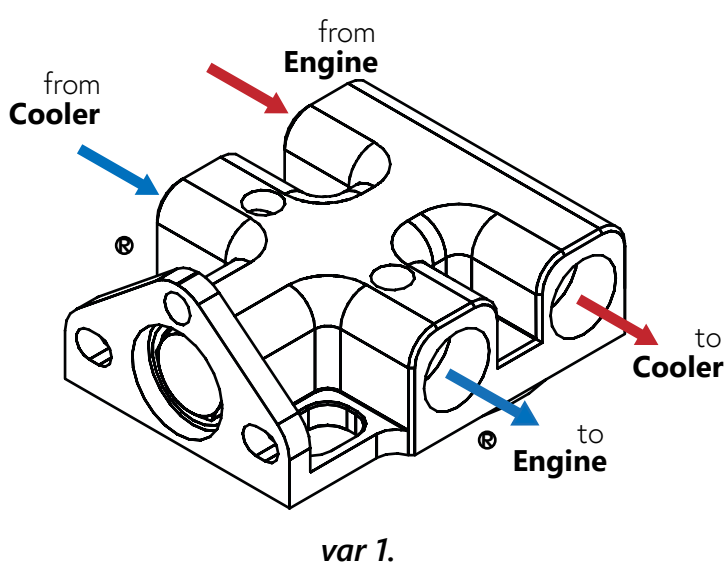

Fitting Instructions

As shown above, the rear ports  can be switched between 'to engine' and 'from cooler'.

The front two ports must always flow the way stated and cannot be reversed. OTRFH1R is right to left and OTRFH1L is left to right

Included parts

- 2x 1/8 NPTF blanking plugs
- 1x 3/4 unf spigot
- 1x Thermostat assembly

Available fittings

- Port adapters to:
- 6 JIC - MMA2-6-105S
 - 8 JIC - MMA2-8-105S
 - 10 JIC - MMA2-10-105S

- 12 JIC - MMA2-12-105S
- 3/8 BSP - MMA5-6-105S
- 1/2 BSP - MMA5-8-105S
- 5/8 BSP - MMA5-10-105S
- 3/4 BSP - MMA5-12-105S

Product Details

- Prevents oil temperature from dropping below optimal levels, improves fuel efficiency by accelerating warm up time while reducing excessive engine wear and loss in horsepower
- Oil flows through filter first (thermostat does not bypass the filter filter is not bypassed by the thermostat)
- A small percentage of fluid, less than 10%, will continually circulate through the cooler. This will eliminate trapped air and prevent the static cold fluid in the cooler from shocking the engine
- Rebuildable
- Thermostat can be changed to alternative temperature
- 3/4 UNF filter thread is compatible with a wide range of filters
- Accommodates oil filters with maximum O-ring outer diameters 78mm
- 6082-T6 billet aluminum construction with black anodized finish
- Female - M22x1.5 ports
- 2x 1/8 NPTF take off ports
- Made in UK

The thermostat is set to send oil flow through the cooler at 80 °C. At lower temperatures, the flow takes the line of least resistance bypassing the colder, thicker oil in the cooler.
The "waxstat" which operates the oilstat will suffer permanent damage if the temperature exceeds 140 °C.

Basic Dimensions

